

Solar-Mio

Solar-Mio

Solar-Mio

Solar-Mio

Solar-Mio

Solar-Mio

Solar-Mio

Solar-Mio

Solar-Mio

Solar-Mio

Solar-Mio

Solar-Mio

Solar-Mio

Australian Owned Company



Solar-Mio

Down-Drain System

INSTALLATION AND OWNERS MANUAL

WARNING: This water heater should be installed in accordance with the requirements of AS 3500.4.

The owner should also be aware of any limitation on the suitability of the solar heater for use with water of specified poor quality, and any need for water softening treatment as per AS 3500.4.

Solar Hot Water

The Clever Solar System



Thank you for purchasing a Solar~Mio solar hot water system. Many years of research have gone into its development to make sure that you have the most reliable solar hot water system on the market.

***PROUDLY DESIGNED AND MANUFACTURED IN AUSTRALIA*
BY**

The Wise Living Group
Respect for People and the Environment

INCORPORATING
SOLAR MIO ~METAL DYNAMICS~THERMALUX
PO BOX 565 ALBURY NSW 2640
AUSTRALIA

www.wiseliving.com.au

PHONE (02)60406666 FAX (02)60406667

General

This manual explains the installation requirements for Solar~Mio
domestic

DOWN-DRAIN

hot water systems

recommendations from Australian Standards form the basis for this manual, however, where there is conflict between the manual and the requirements of any regulating authority, the latter shall prevail.

IMPORTANT: READ THIS PAGE!!

The Solar-Mio Down-Drain system is a pump operated system that allows the solar collectors to drain completely when the system is not heating.

The pump is turned off automatically if there is no heat input from the collectors, also if the storage tank is up to temperature or if frost conditions apply.

The Down-Drain system affords the best frost and over temperature protection available.

For a Down-Drain system to operate, the whole of the collector **must** be higher than the storage and makeup tank (i.e. The bottom of the collectors must be higher than the top of the storage and makeup tanks) and the flow and return pipes should have fall back to the tank to ensure complete draining of the collectors.

The make-up tank needs to be correctly sized to suit the number of collectors.

Solar Collector(s) Installation

Solar Mio Panels come in two types: **(Fig 1)**

NOVA. These collectors are mounted vertically on the roof and are the normal for most installations.

SQUAT: These are the same size as the Nova collectors however they are mounted horizontally. The Squat collectors are used where there is insufficient height between tank and collectors to allow for adequate thermosiphoning or on pump operated systems where space is an issue.

Location of Solar Collectors

Shade: Collectors should be located so as to be clear of shade for at least 3 hours either side of solar noon (12 pm Standard Time). Partial shading due to small objects e.g. antennas and flues is permissible during this period.

Position relative to Hot Water Tank: Collectors should be as close as possible to the hot water tank, but must be higher than the tank.

Orientation: Collectors should face (orientate) true north in the southern hemisphere and true south in the northern hemisphere, wherever practicable.

In Australia deviation from north will reduce performance depending on the amount of deviation and the latitude. Deviation up to 45° will reduce performance by up to 5%. Deviation greater than 60° is not recommended.

Inclination: Collectors theoretically should be inclined at a similar angle to the latitude angle of your location. Deviation from this angle by +20° or -20° reduces performance by only 5%. Practical considerations therefore favour flush mounting the collectors on pitched roofs.

The collectors should also be mounted with the outlet side slightly higher than the inlet. Collectors should be mounted with a 25mm per metre rise **(Fig 2)**.

IMPORTANT

Ensure that the roof is of adequate strength, the collectors weigh approx 38 kgs each, including the water content.

Ensure all screw holes and pipe entry points are sealed and weatherproofed to prevent entry of water.

Solar Collector (s) Installation

Pitched Metal Roof (Fig 3)

Locate and fix the top mounting brackets to the roof using a straight edge to ensure alignment. The brackets are the same length as the collectors; a gap of 70mm should be left between adjacent brackets to allow for the connectors which join the collectors together. The brackets should not run level but should rise slightly toward the hot water outlet end of the collector bank. This will help to eliminate air when the collectors are installed. Rivets or screws should be used for fixing to the metal roof and then sealed with a neutral cure silicone. Silicone should also be used between metal/metal interfaces to prevent corrosion. Bolt the tabs provided onto the top corners (**Fig 3A**) of each collector. Position the collectors on the roof by hooking the top tabs over the brackets previously located on the roof. Join the collectors with the 1" copper connectors provided then screw the tabs onto the top brackets. Locate and fix the lower brackets to the collectors first and then to the roof as for the top brackets.

Flat Metal Roof (Fig 4)

If installing onto a flat roof a Solar Mio flat roof mounting frame can be used to enable the top of the collectors to be mounted at a suitable angle. The mounting tabs are fitted to the panels in the normal way, and the mounting frame is fitted to the tabs. The bottom mounting bracket is then fixed to the roof using suitable screws (not supplied).

The top mounting bracket is not used, the mounting frame is screwed directly to the mounting tabs with the base then screwed directly to the roof using appropriate sized mounting screws (not supplied) (**Fig 4A**).

Tiled Roof (Fig 5)

Install the bottom bracket first by sliding up, or removing tiles in the desired location. Attach strips of strap iron (not supplied) as shown in (**Fig 5**) and replace the tiles. Attach the bracket to the strap iron. The brackets should not run level but should rise slightly toward the hot water outlet end of the collector bank. This will help to eliminate air when the collectors are installed. Place the collectors on the roof and let them rest against the bracket. Connect the bottom of the first collector to the angle bracket with the tabs. Bolt the tabs to the collector using the 6mm bolt supplied and then screw tab to the bracket with the TEK screw supplied. Join the next collector to the first collector with the 1" copper connectors before securing it to its angle bracket as per the first collector. Repeat the above until all the collectors are connected to their respective brackets. To secure the top of the collectors to the roof, bolt and screw the remaining brackets using tabs to the top of the collector(s). Attach strap iron to rafter or battens above the collector(s) by removing the tiles as described above. Screw or bolt the brackets to the protruding strap iron and replace tiles.

Panel position: Never allow shrubs or other large obstacles to cast shade on the solar collectors. Collectors, if shaded, will not function correctly. This should be checked annually under both summer and winter conditions. Shading from newly erected buildings would also need to be considered and collectors re-located if necessary.

Heavy atmospheric fallout which settles on the solar collector glazing will also reduce performance. This seldom occurs, but if it does, clean them with water and detergent. Carry out this cleaning operation only when the collectors are cool, that is, at the beginning or end of the day or during overcast conditions.

Tank Installation

Tank Position: The tank should be positioned as close as possible to the most frequently used hot water outlet point and also minimise the pipe runs to the collectors. The storage tank and makeup tank must be below the collectors.

The thermostat on the tank should be set at a minimum of 60°C

ROOF MOUNTED TANKS

Tanks must be placed on a strongly constructed flat, level platform in a properly drained safe tray in accordance with AS 2002-1987 considering the weight of the tank plus water (1 litre=1 kg). This platform should be positioned so that the load is supported over one or more soundly constructed load bearing walls or a suitably designed beam, roof truss or similar substantial support.

The tank must be separated from the safe-tray by the use of timber battens with a minimum thickness of 12mm. These should be evenly spaced and in contact with 60% of the base of the tank whilst just projecting past the tank base perimeter (**Fig 6**).

Constant or low pressure tanks: As the domestic hot water flow produced by these tanks is proportional to their height above hot water outlets, they should be elevated as high as possible in the building and as close as possible to the hot water draw-off points.

Calorifier/MP Tanks: The domestic hot water flow from these type of tanks is not dependant on the height above the outlet points and they should be placed as close as possible to the hot water draw off points.

FLOOR OR GROUND MOUNTED TANKS

Medium (Fig 6A) and Mains (Fig 6B) Pressure Cylinders:

Floor and ground mounted tanks must be placed on a strongly constructed flat, level surface. Internal tanks should have a properly drained safe tray in accordance with AS2002-1987. External weatherproof tanks should sit on a concrete pad or equivalent.

Pipe work & Fittings

With solar collectors and tank fixed in position, pipe runs can be fitted off using lagged weather-proof 1/2" copper pipe. Keep pipe runs as short as possible to reduce heat losses. All connections to the collectors are by Neoprene rubber "O" ring and therefore minimal torque is required to be applied to these connections to achieve a seal. Do not use Teflon or hemp. Connections to the 1/2" copper pipe are by flared compression fittings (supplied). Unless otherwise specified for special design systems, bottom solar connection on the tank connects to the bottom connection on the solar bank and the top connection on the tank connects to the top connection on the solar bank. The pump is positioned in the cold (bottom) pipe, flow direction towards the collectors and as close to the tank base as practicable.

Pump and controller

The controller is a differential thermostat which turns the pump on and off in response to temperature signals received from a hot sensor, located in the hot sensor well in the solar collectors on the roof and a cold sensor located either in a pocket at the base of the tank or in the case of a mains pressure system into a pocket on the return fitting on the tank. **It is crucial that these sensors be run with care so that they are not damaged or cut.** The controller performs three functions:

- (1) Normal— when temperature difference between top of collector and base of tank is 9°C the pump is switched on. When this temperature difference drops to 5°C the pump switches off.
- (2) Freeze protection – when the temperature in the collectors drops the pump switches off and the water drains from the collectors.
- (3) Over-temperature— when tank temperature reaches 80°C the pump is switched off. Any pressure buildup in the collectors is relieved by the relief valve and the collectors will then drain. This facility guards against water loss from the system.

Pump And Controller Installation

The circulating pump and control unit should be mounted out of weather onto a vertical surface; the wall adjacent the tank for preference, or onto the tank itself. Arrows embossed on the pump body and the check valve on the discharge side of the pump indicate the direction of flow; they should always point upwards. This means that air will never lodge in the pump and the axis of the pump motor will be horizontal, which is the correct orientation. See for pump orientations page 14.

The hot sensor (long lead) should be pushed into the hot sensor well on the solar collector to the full depth. A small "dob" of silicone sealant should then be used to seal around the entrance to the well to prevent ingress of moisture etc.

The cold sensor (short lead) should be located into the well at the tank or the cold flow pipe. Sensor leads should be run and held in position using cable ties.

The pump lead is plugged into the controller and the controller should be connected to a 240V AC power supply (G.P.O—General Power Outlet) at all times .i.e. throughout the year .

Frost Valves

A frost valve should be installed as per drawings. Once installed the valve body should be swivelled downwards as far as possible to permit total drainage, but maintain a minimum gap of 40mm between the discharge point and the roof. During frosty conditions these valves open and allow a flow of water back into the makeup tank.

Start Up

Fill the system with water, check for leaks and turn the controller on at the power outlet. If the weather is fine, the pump will quietly run. Warm water will be felt returning from the collectors. It may be necessary to bleed the air from the collector to achieve complete flooding. If the weather is bad, temporary disconnection of the hot sensor from its connection at the control box will also make the pump run for test purposes. Be sure to reconnect it after testing.

SOLAR MIO COLLECTORS 5 YEAR WARRANTY

Wise Living warrants their solar collectors to be free from defects in materials and workmanship and under normal use and service in accordance with the attached installation and operating instructions and within 5 years from the date of original purchase on the terms herein shall repair or replace without cost to the original customer any part thereof which shall be returned to our factory or designated agent, transportation charges prepaid and which our inspection shows to be thus defective.

This warranty does not apply to glass breakage or the discoloration of the surface or tarnishing of fittings, all of which require normal service to maintain them.

Wise Living warrants the Pressure Temperature Relief Valves, Anti Reverse Circulation Valves, pumps and controllers, where fitted, to be free from defects in materials and workmanship and under normal use and service in accordance with the attached installation and operating instructions and within 12 months from the date of original installation on the terms herein shall repair or replace without cost to the original customer any part thereof which shall be returned to our factory or designated agent, transportation charges prepaid and which our inspection shows to be thus defective. All valves, pumps and controllers require normal service to maintain them.

Under the terms of this warranty, Wise Living assumes no responsibility for the labor costs involved in removing or replacing the above items, nor shall Wise Living be liable for any injury, loss or damage (direct, indirect or consequential) arising out of the use or inability to use the product or its removal and replacement. All other warranties expressed or implied are excluded to the extent possible at Law. Consumers also have rights under relevant State, Commonwealth and Federal laws.

Fig. 1

**Solar Collector Styles
and Sizes**

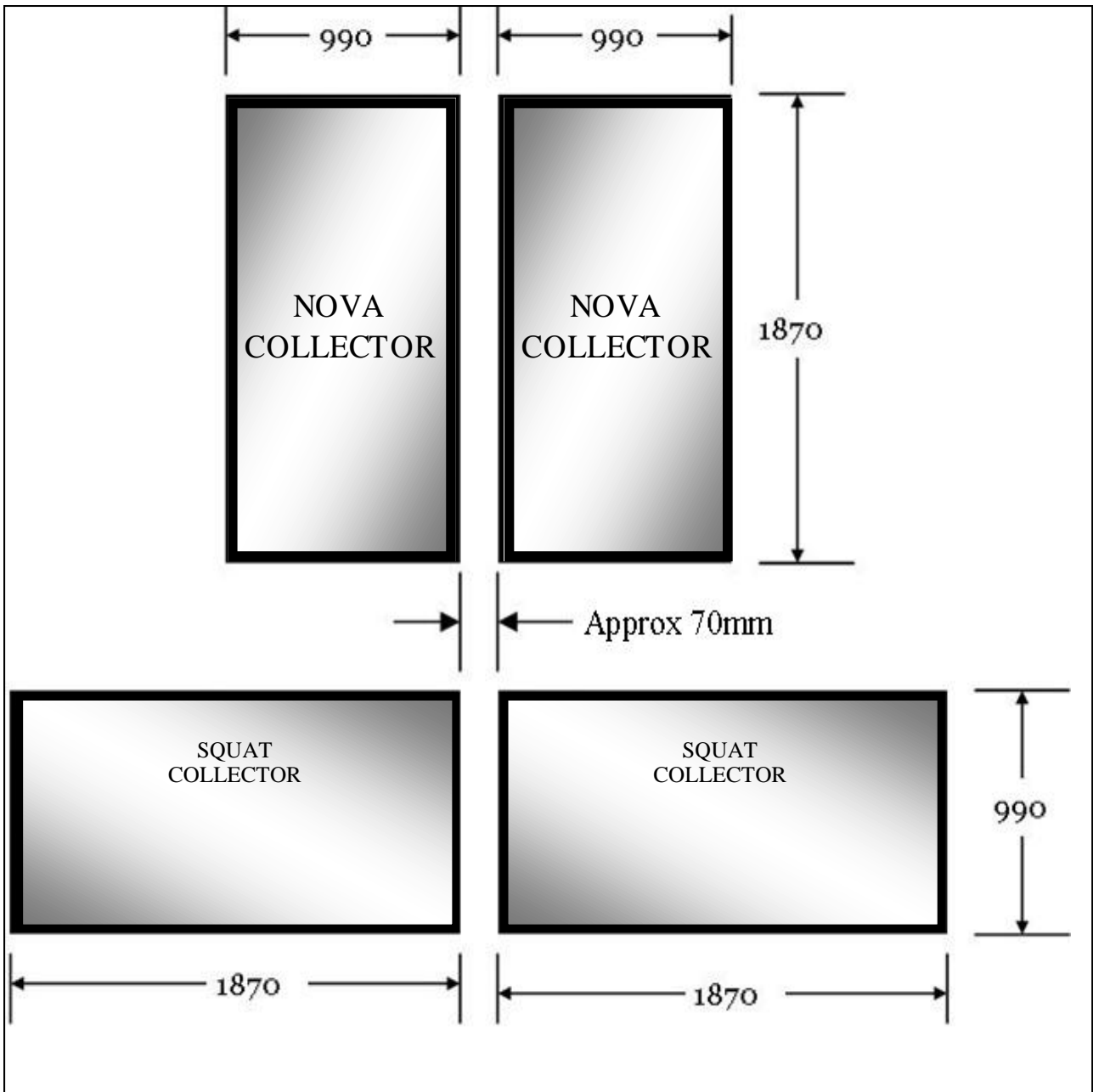

Fig. 2

**Solar Collector
Rise Angles**

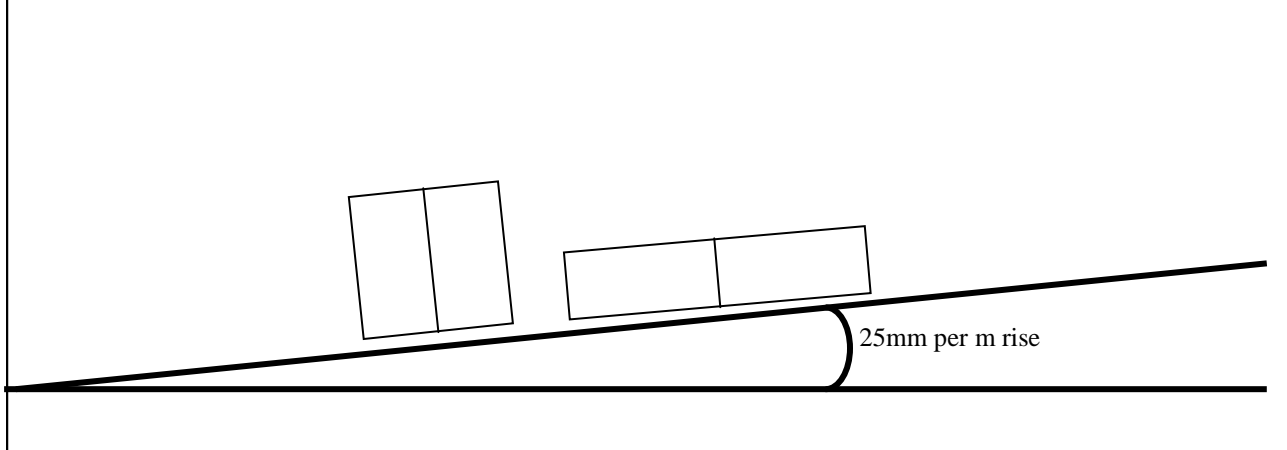

Fig. 3

**Mounting Solar Collectors on
Sloping Steel Roof**

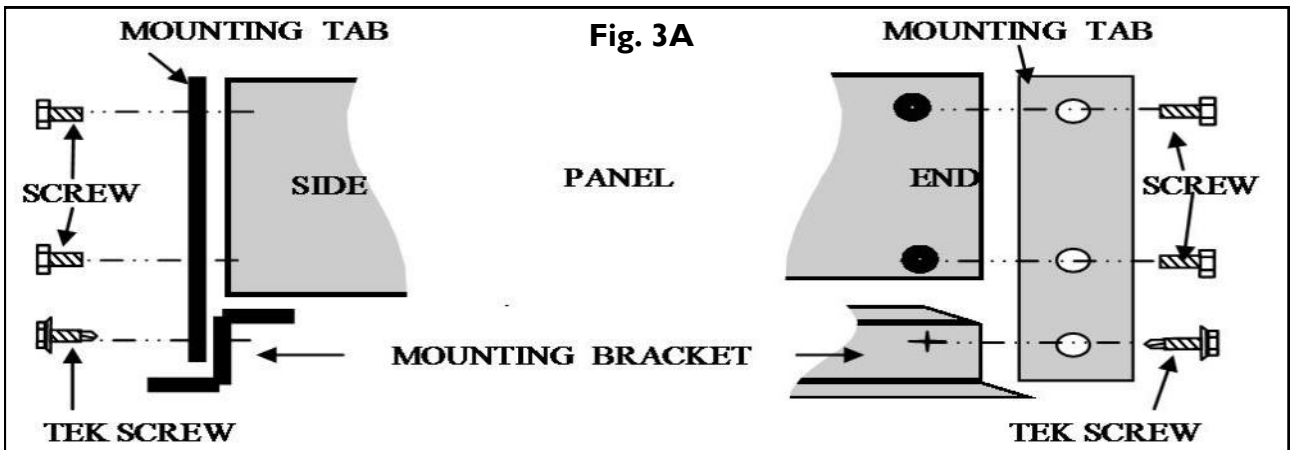
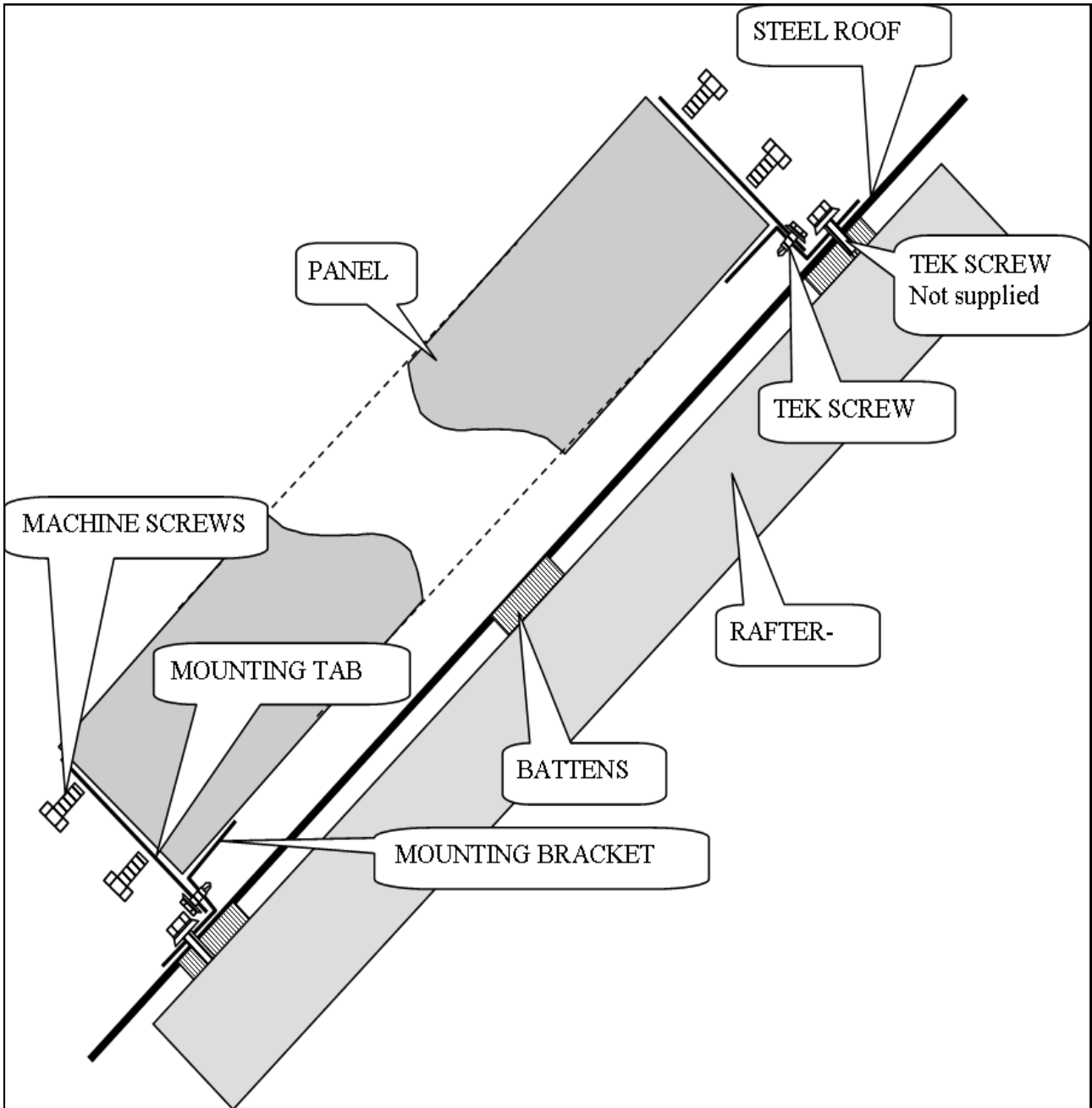

Fig. 4

Mounting Solar Collectors on Flat Metal Roof

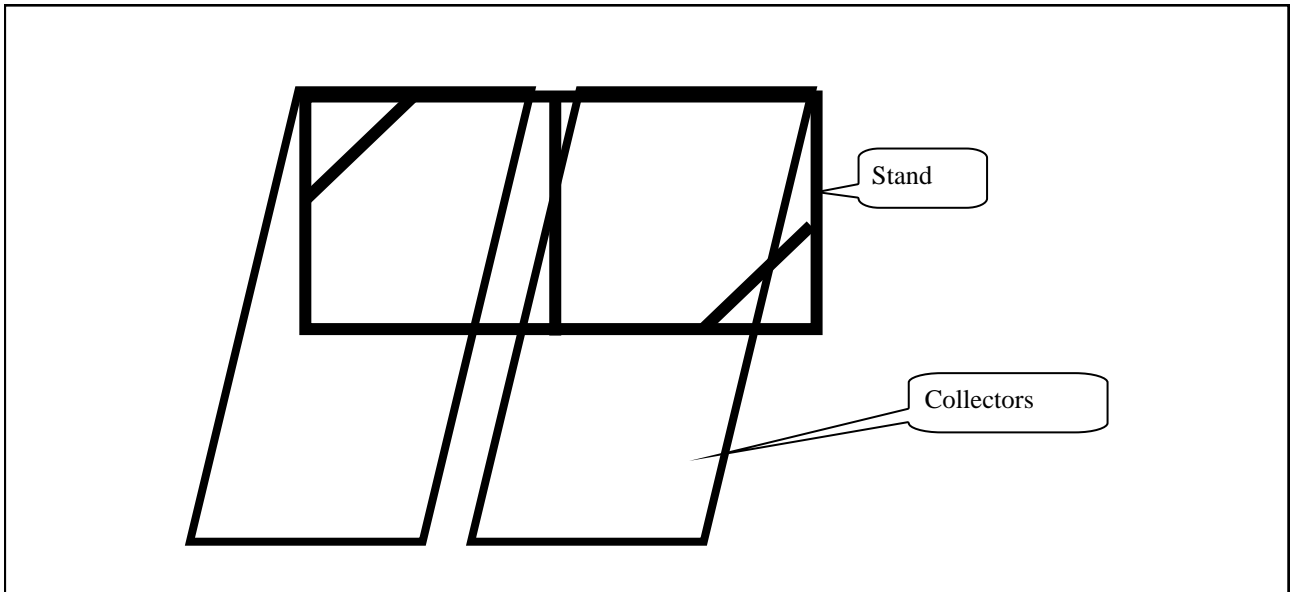

Fig. 4A

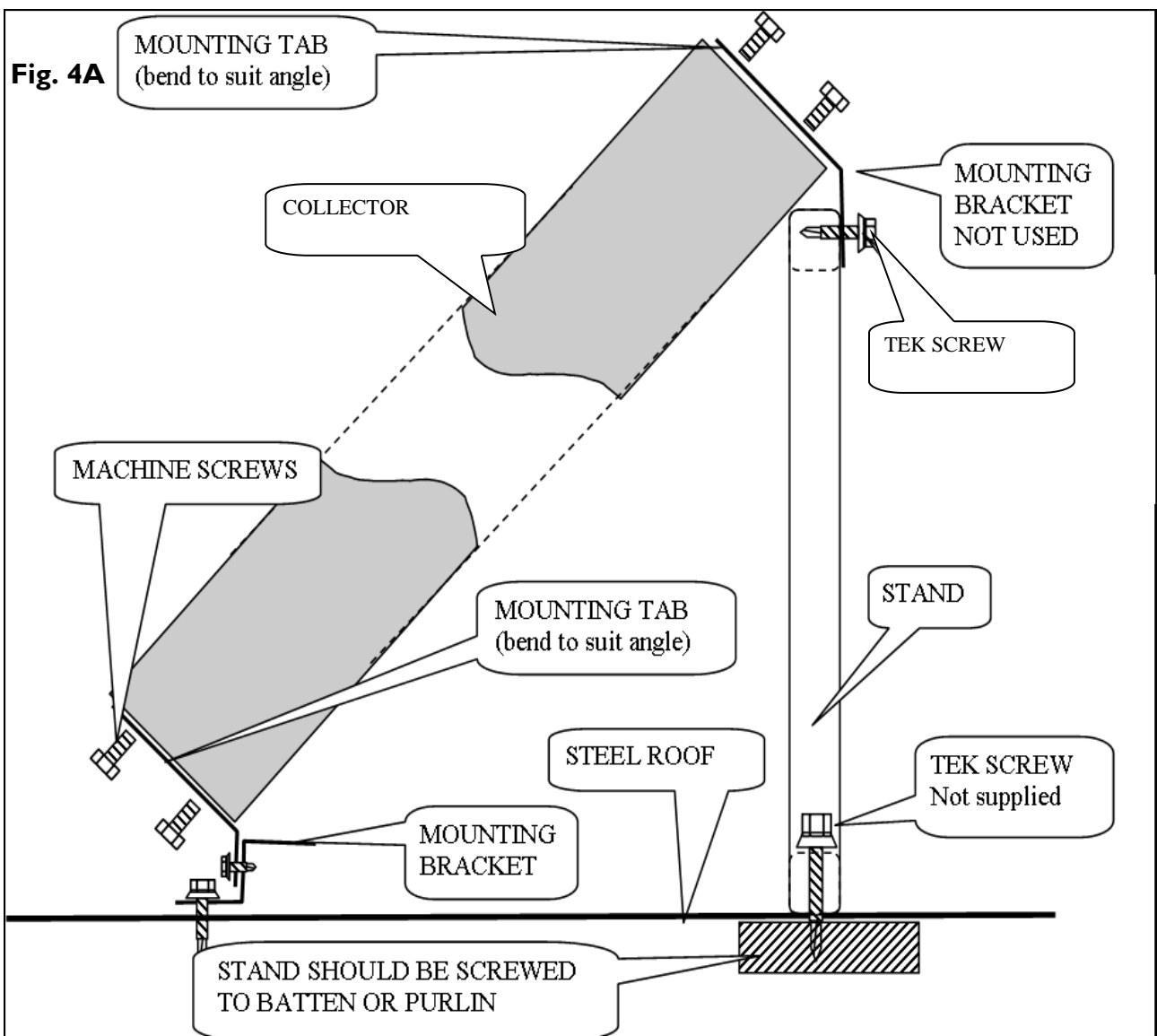

Fig. 5

**Mounting Solar Collectors on
Tiled Roof**

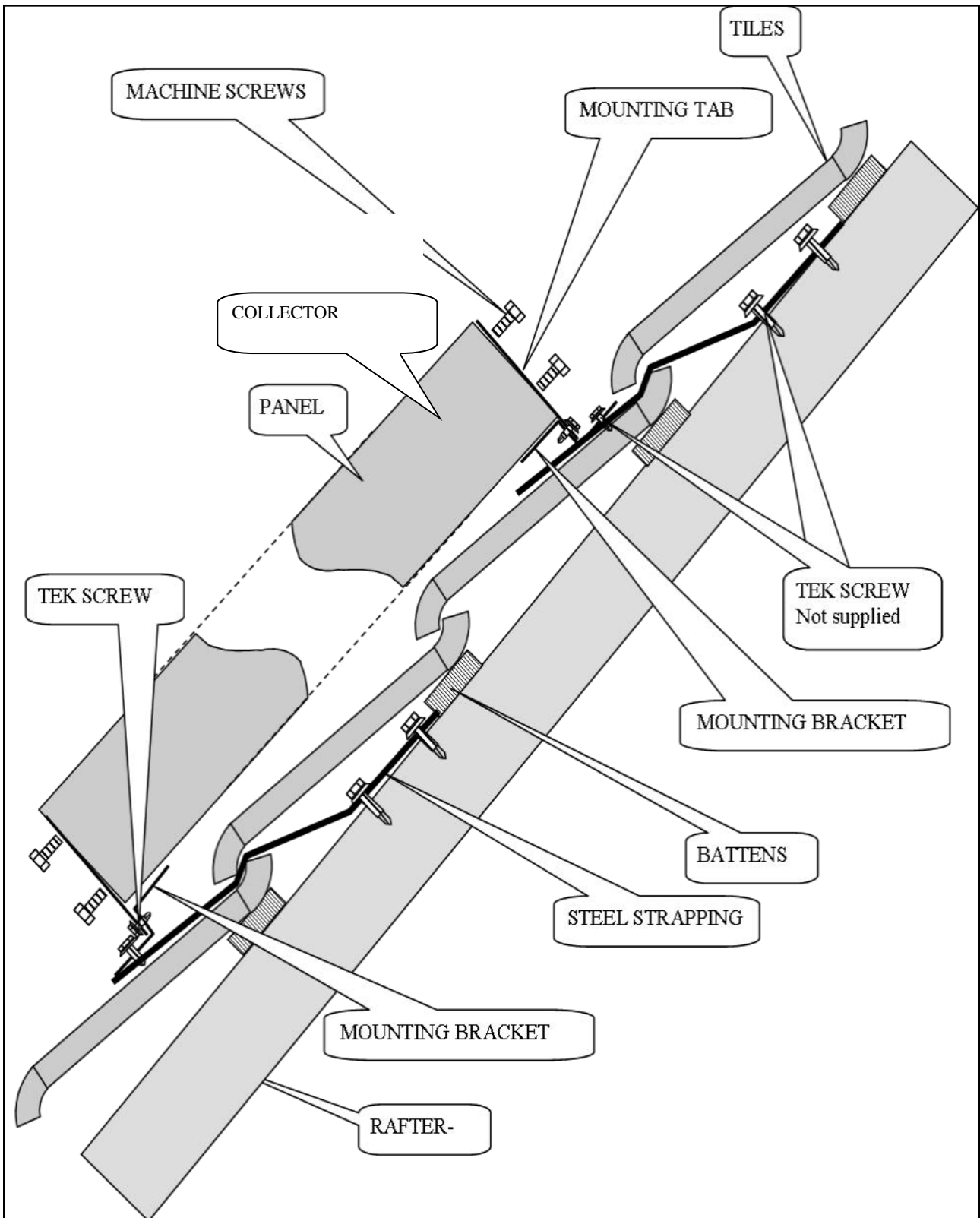

Fig. 6

Low Pressure or MP tank

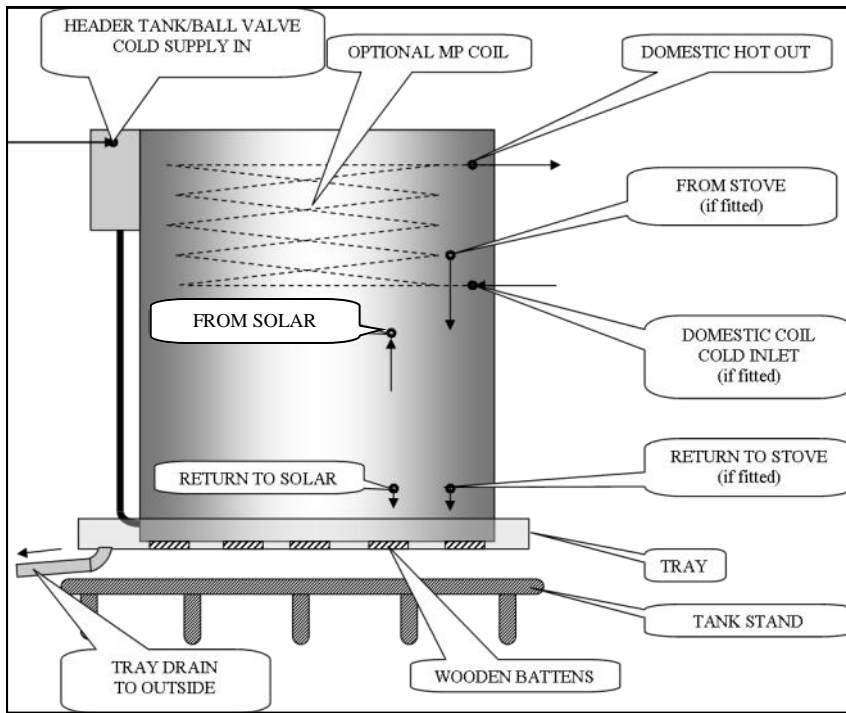
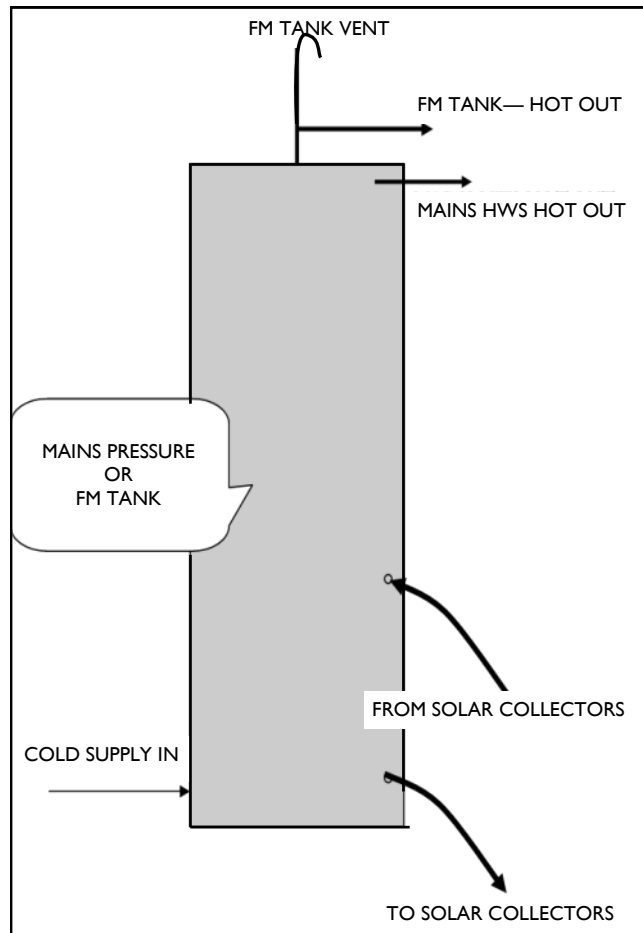

Fig. 6A

Medium Pressure FM Tank



For complete tank installation instructions please refer to the installation manual supplied with your tank

Fig. 6B

Mains Pressure tank

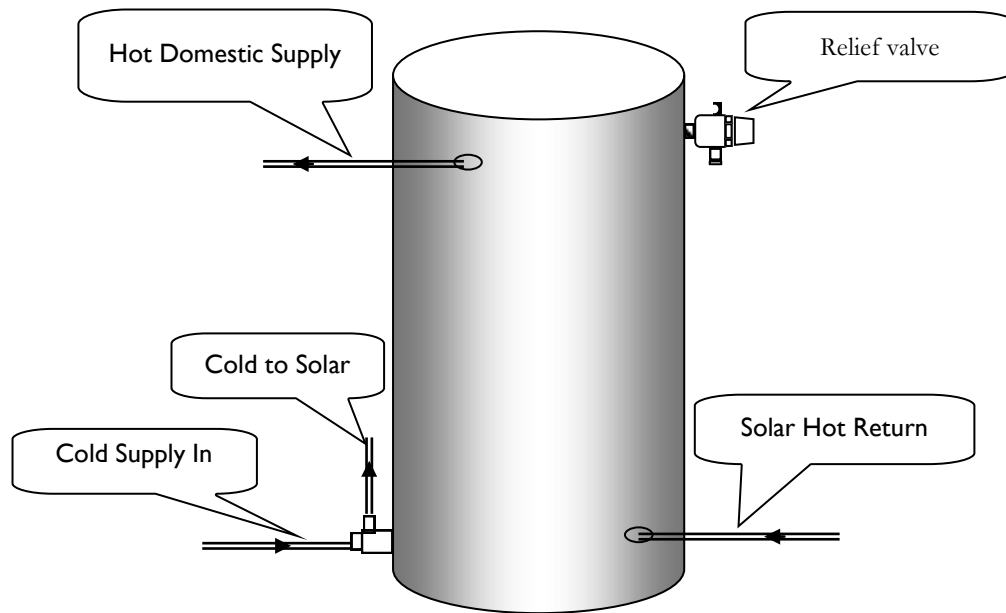
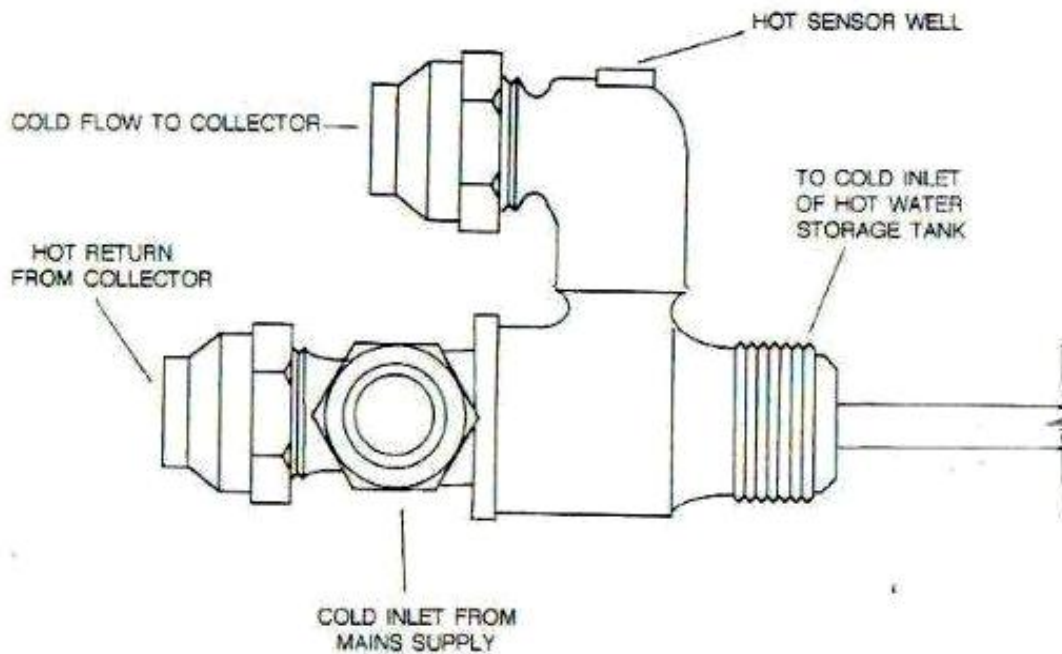

Fig. 7

**Solar Mio
5-Way Valve**



IMPORTANT NOTE TO INSTALLER

DO NOT REMOVE RUBBER TUBE STIFFENER UNTIL AFTER FIVE WAY FITTING IS IN FINAL POSITION IN STORAGE TANK. IF ANY ADJUSTMENT IS REQUIRED RE-INSERT THE STIFFENER. THIS IS REQUIRED TO PREVENT TWISTING OR KINKING OF TUBE WHICH WILL PREVENT WATER FLOW.

Dynamic Series

****IMPORTANT****

PLEASE NOTE:

ENSURE THAT THE PUMP IS NOT INSTALLED WITH THE PUMP'S ELECTRICAL MOTOR

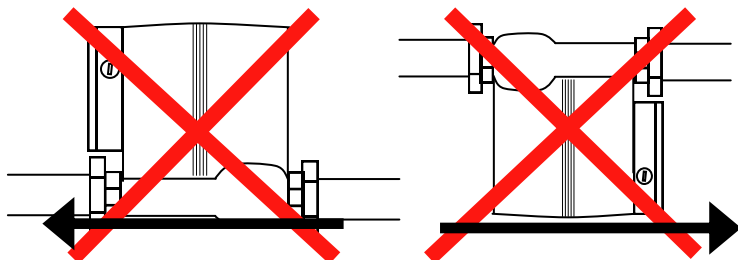
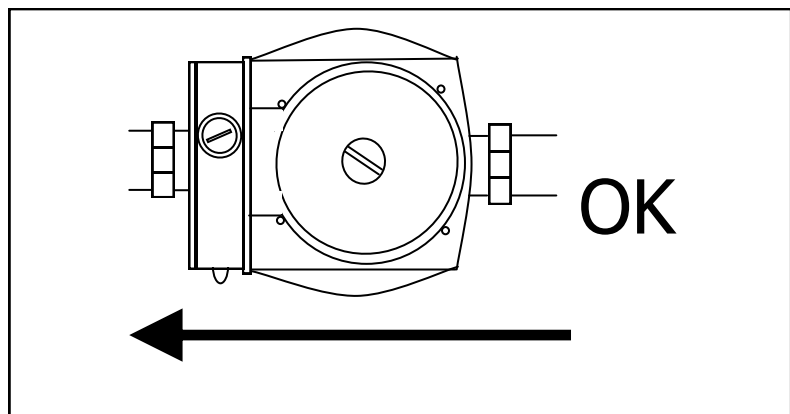
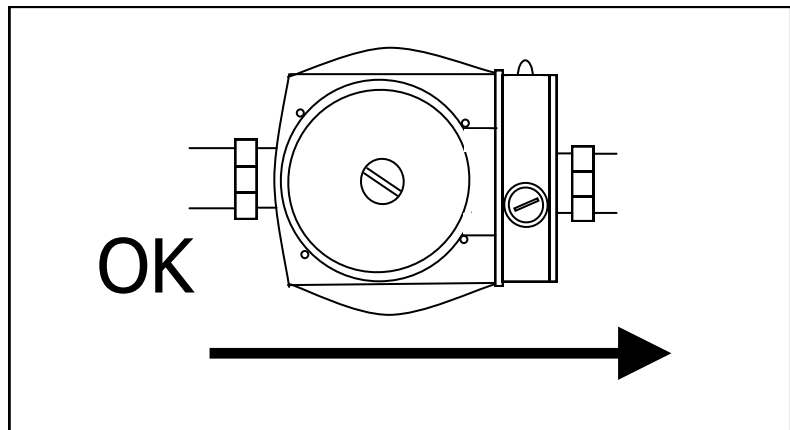
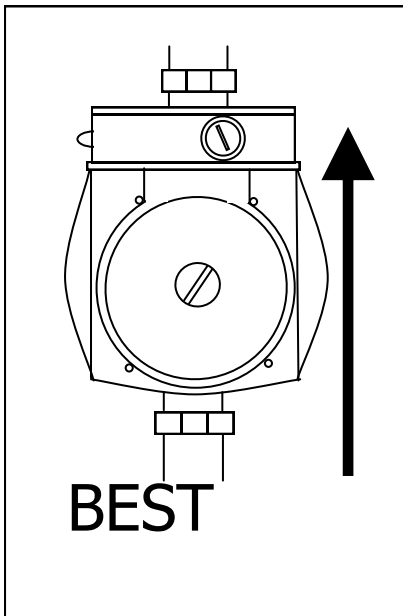
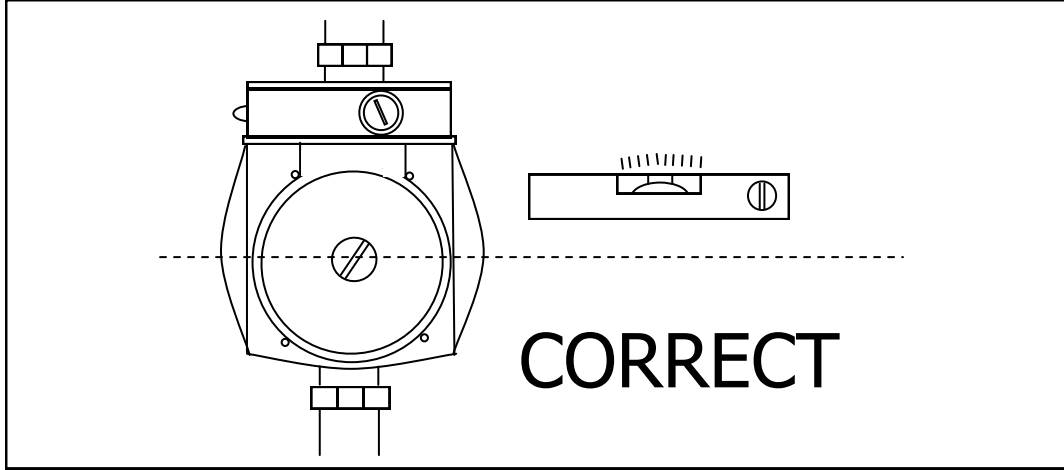

Solar-Mio Down Drain Pump-Operated Solar System

NOTE: The bottom of the collector must be above the top of the tank and header tank.

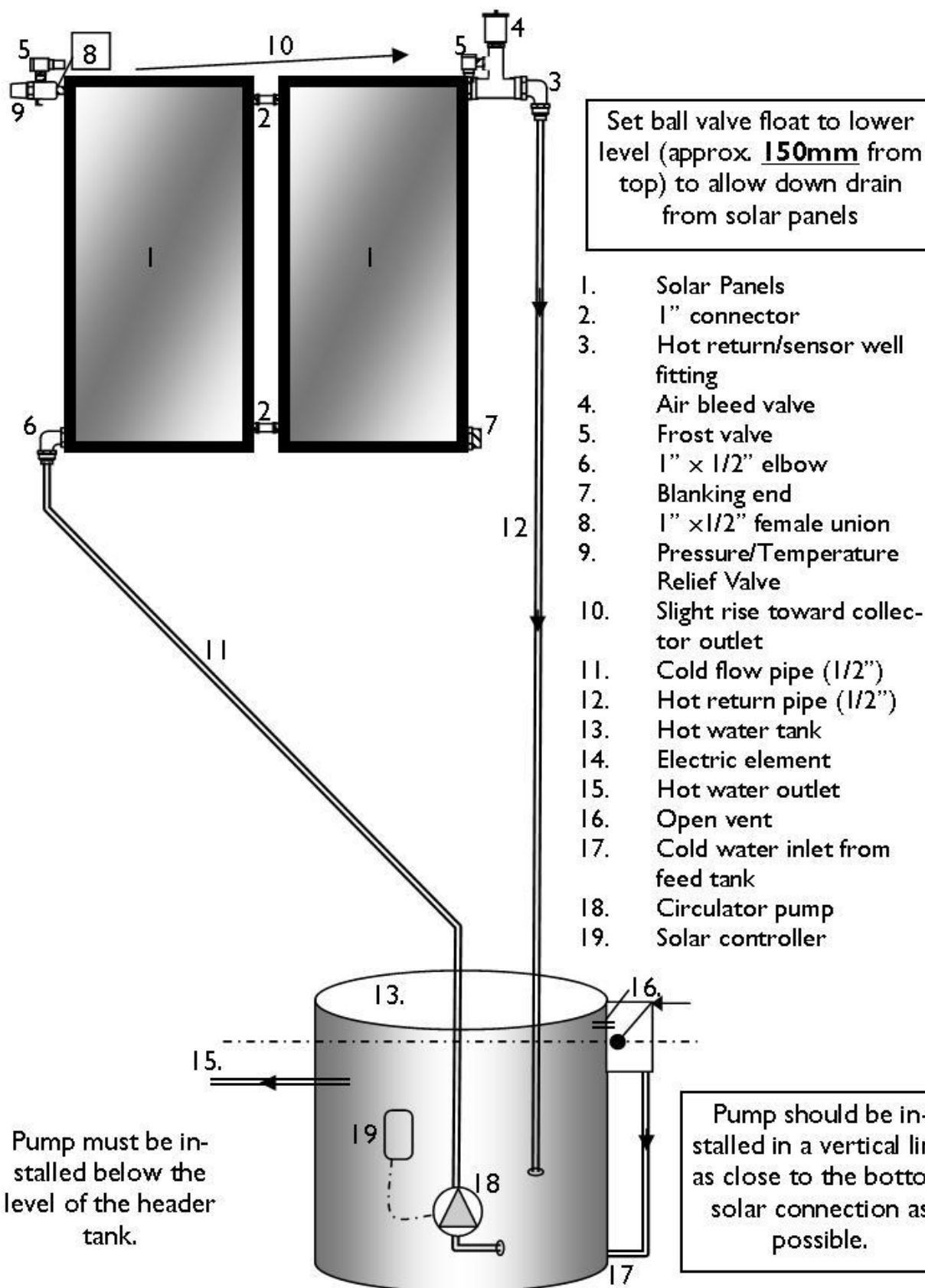

Floor-Mounted Medium Pressure Tank

NOTE: The bottom of the collector must be above the top of the tank and header tank.

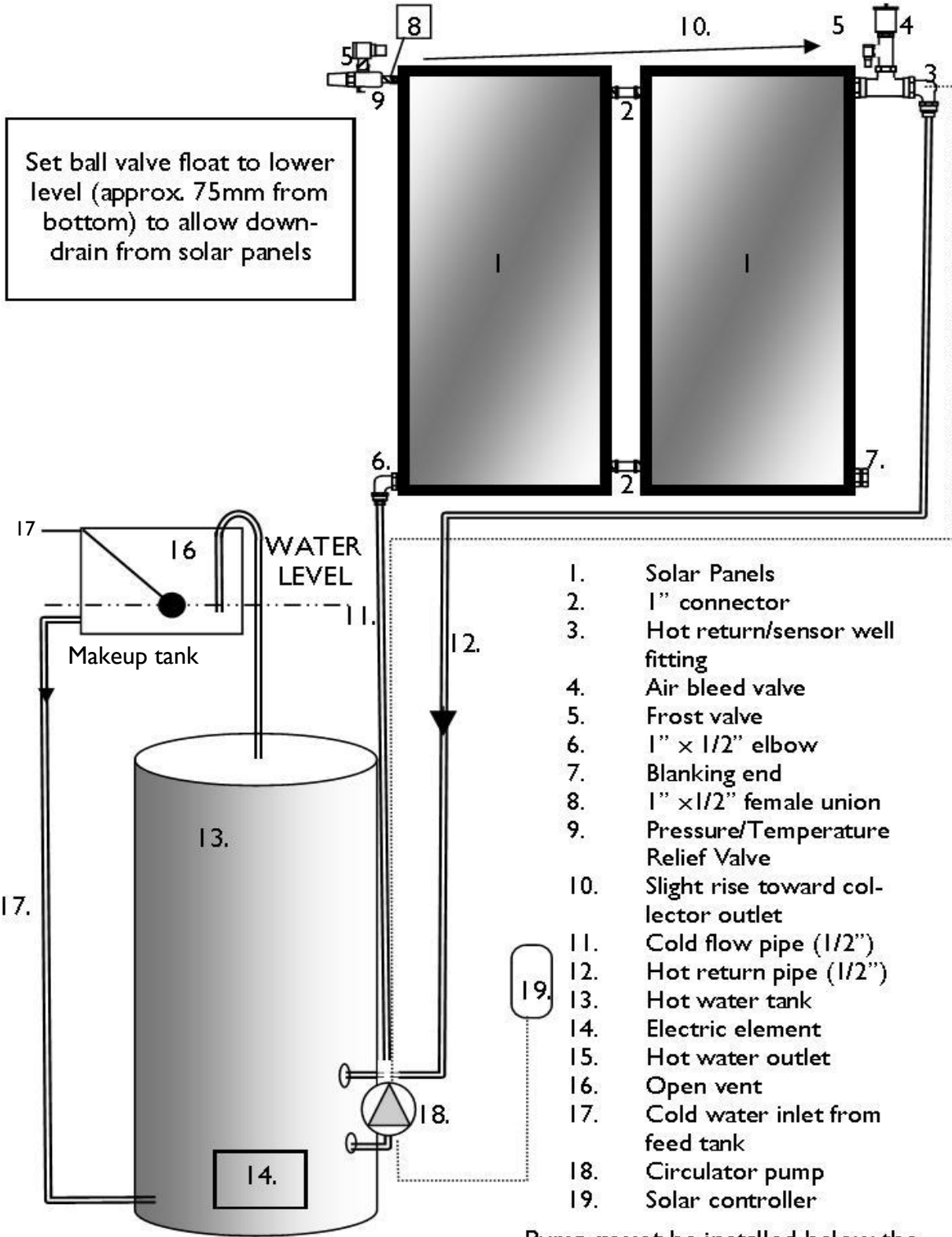

Pump must be installed below the level of the makeup tank.

MAINS PRESSURE

NOTE: The bottom of the collector must be above the top of the tank and makeup tank.

1. Solar Collectors
2. 1" connector
3. Hot Sensor Well
4. Brass bush
5. Blank End
6. Auto Air Bleed
7. Frost Valve
8. 1 x 1/2" elbow
9. Roof flashing
10. Pressure Relief Valve
11. Cold flow pipe (1/2")
12. Hot return pipe (1/2")
13. Hot water tank
14. LFC Heat Exchanger
15. Hot water outlet
16. Cold water inlet
17. Makeup tank
18. Circulator pump
19. Controller
20. Vent pipe

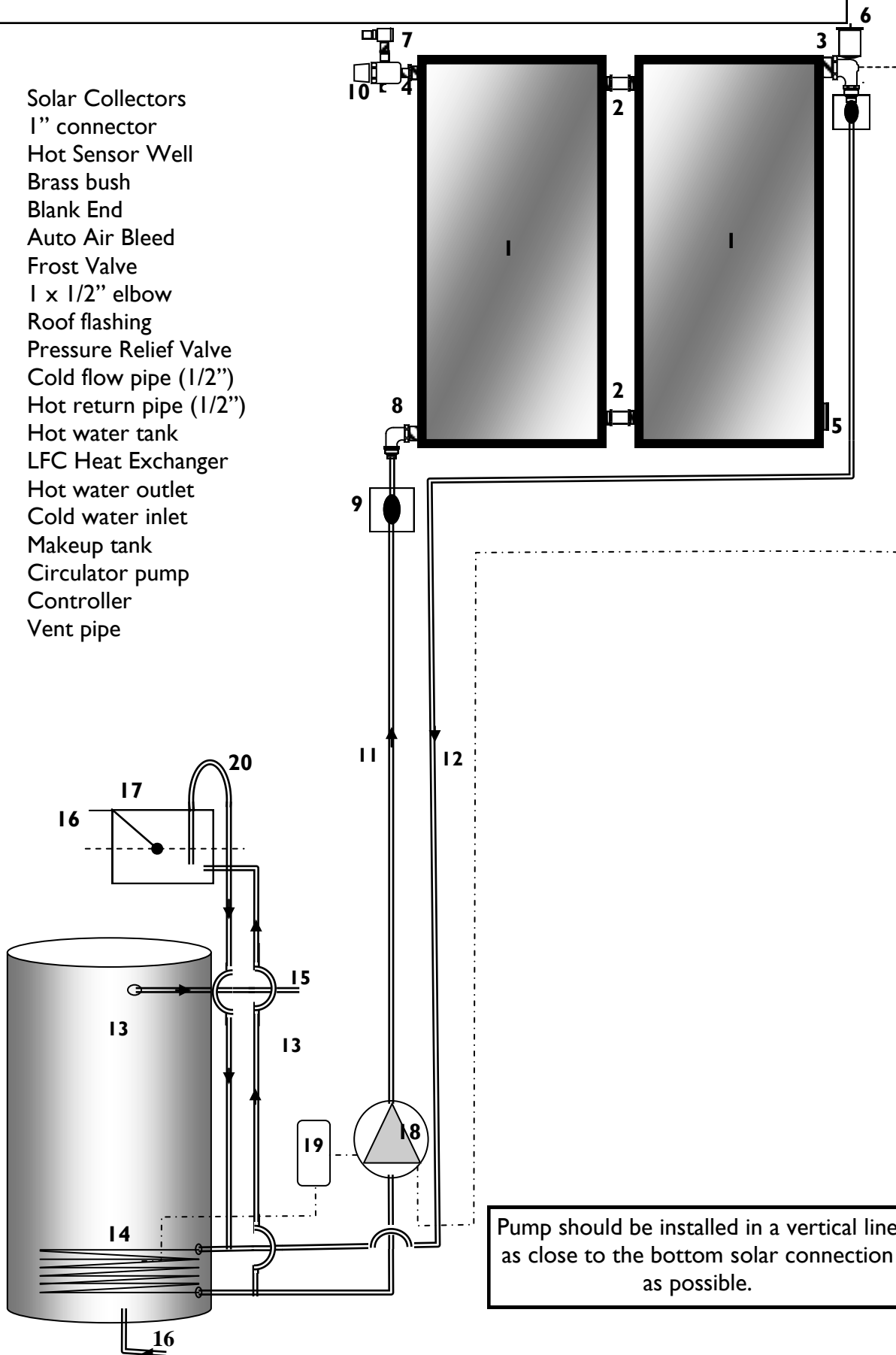

Pump should be installed in a vertical line as close to the bottom solar connection as possible.

General Technical, Installation and Maintenance Information and Requirements

Hot Water Storage cylinders:

Low Pressure, Constant Pressure and MP Calorifier Tanks are open vented and therefore not pressurised.

Medium Pressure FM hot water tanks must be open vented with a maximum head pressure of 7 metres (70Kpa).

Mains Pressure hot water storage cylinders require the fitting of a 500KPA or lower pressure reduction valve & 750Kpa or 850Kpa PTR Valve.

Solar Collectors:

The collectors maximum operating pressure is 1000KPA.

Down Drain System —Total Frost & Over Temperature Boil Protection.

Draining The System:

WARNING: The system may contain extremely hot water. Exercise caution to prevent scalding. When system is hot, check that escaping water will find its way safely to ground and not deform plastic gutters and downpipes where fitted.

1. Turn off the electric elements and/or gas supply where fitted. Turn off the solar pump.
2. Ensure that wood fired or oil boilers are not operating.
3. Turn off the cold supply to the tank.
4. On Mains pressure systems. Release and leave open the Relief Valve.
5. Open the Relief valve on the solar collectors.
6. Undo any fitting at the base of the storage tank.
7. The system will now drain.

Reverse the above procedure to refill the system.

Poor Water Quality Areas:

In areas with high or low pH, above average salt, calcium or mineral content a suitable water filter and/or water softening device may be required. Refer to your local plumber or place of purchase.

**General Technical, Installation and Maintenance
Information and Requirements**

Glass Breakage Replacement

In case of glass breakage, replacement is only recommended by a licensed tradesperson and at ground level. Assistance can be provided by the system manufacturer.

Expansion Relief Valve

The Solar system may drip small quantities of water from the expansion relief valve – this is normal during normal operation. Continuous leaking from the expansion valve may indicate a problem with the system.

If the expansion valve is continuously leaking, try easing the valve gear which may remove any foreign matter caught in the valve, alleviating the problem.

For turn knob expansion valve - twist cap until water flows from drain line.

For lever expansion valve - lift lever until water flows from drain line.

Using the Relief Valve to bleed the system

CAUTION: Scalding water or steam may escape when valve is open.

When using a turn knob pressure relief valve to bleed a system you will need to rotate the easing knob slightly so as to hold pressure against the return spring. Manually hold the valve open until all the air has escaped and water flows freely. If you turn the knob too far it will automatically close.

Tempering Valves

The installation of tempering valves will reduce the temperature of the hot water supplied to the hot water taps. These valves may be required to be fitted on the installation. It is recommended you speak to a licensed plumber/installer about your requirements for tempering valves.

PLEASE NOTE:

All systems have been designed and tested to provide trouble free hot water for many years providing they are installed correctly.

Most problems relating to the functioning of the solar system are related to incorrect installation. As the manufacturer we have no control over installation and therefore cannot take any responsibility for incorrect installations. Warranties only extend to faulty product and do not cover the installation.

We at Wise Living Products are happy to work with your licensed plumber to overcome any installation problems that may arise.

Problem Solving for Non-Performing Systems

Is there power to the pump and controller?

Check the pump is plugged into the controller and the controller is plugged into the power point and that there is power at the power outlet.

Controller light stays on continually?

The light on the controller indicates when the pump is running. If controller light is constantly on (for days), this could indicate a problem in the sensor leads. Check sensor leads are correctly fitted. Also check for damaged cables, i.e. rodent damage.

Solar is not running during the day when maximum solar contribution is available?

1. The hot water service is already at temperature—if you have an electric element connected, check that it is on night rate or turned off during the summer months. To get maximum solar contribution, you may look at turning off the power to the hot water service during the summer months or use hot water in the morning, such as showering or washing.
2. Hot sensor lead may not be fitted properly in the sensor well. Check that the sensor is inside in the sensor wells. Hot sensor can be found on the top connection of the solar collectors. And the cold sensor is located at the tank, usually on the “cold flow to solar” line (refer to instruction manual).

Must I fill the collectors as soon as they are installed?

No, unless you want hot water!

Should I cover the collectors during installation?

No.

It's easy to see why more people prefer Solar-Mio



 **Solar-Mio**

SCORCHER

www.wiseliving.com.au



“SOLAR SCORCHER” SOLAR THERMAL HOT AIR TRANSFER SYSTEM

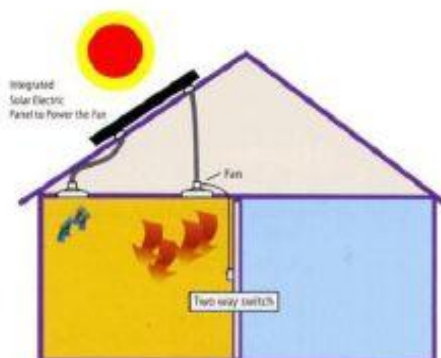

The “Solar Scorcher” offers the home owner the alternative of a solar hot air room heater powered entirely by the sun to provide room space heating.

The large heat collector also contains an integrated solar power cell which not only runs the fan but also contributes to the “Scorchers” heating ability. The “Scorchers” is a low cost easily installed heating option requiring no plumbing or electrical connection.

The system comes complete with all brackets, roof seals, ducting, vent and a two speed fan and switch. Pre-filtered air can be sourced from outside or recirculated from the room being heated.

The system can also be provided with an option that will remove unwanted summer heat from ceiling voids more efficiently than standard roof vents giving the “Scorchers” year round application.

Australian Owned Company

Solar-Mio

Solar-Mio

Solar-Mio

Solar-Mio

Solar-Mio

Solar-Mio

Solar-Mio

Solar-Mio

Solar-Mio

Solar-Mio

Solar-Mio

Solar-Mio

Solar-Mio

The Wise Living Group

Respect for People and the Environment

Incorporating
SOLAR MIO ~METAL DYNAMICS~THERMALUX
PO BOX 565 ALBURY NSW 2640
AUSTRALIA
www.wiseliving.com.au
Phone: (02)6040 6666 Fax: (02)6040 6667

Solar Hot Water

The Clever Solar System

